

# CHRISTIE

## ICON Cabinet Standard All-access Barbecue

The ICON barbecue cabinet is a modern interpretation of our industry-defining Modular Cabinets. The contemporary aesthetic incorporates current trends and legislative requirements around sustainability, inclusivity, and occupational health and safety.



### KEY FEATURES:

- Disability Discrimination Act (DDA) compliant, enabling seated and standing users of all abilities to cook
- Sleek low-profile benchtop with large food preparation space
- Split doors with a raised waste container for ease of removal and cleaning
- Quick-release doors for service, cleaning or changing the swing direction
- All components and panels can be replaced on site
- Explicitly designed for use with our celebrated high-efficiency CC2 cooktops
- Corrosion resistant, low maintenance 304-grade stainless steel construction
- Flat-packed for easy site access and reduced freight costs
- Fast, simple assembly by any competent person

### COLOUR OPTIONS:

Brushed  
stainless steel

Monument  
powder coat

Weathered Steel  
powder coat

Off-the-shelf finishes with five day lead times: #4 Brushed stainless steel; Dulux Weathered steel or Monument powder coating. Click [HERE](#) to view more powder coating colour options (lead times apply).

### ACCESSORIES:



# ICON Standard Cabinet

**Dimensions:**

Width 945 mm  
Depth 1000 mm  
Height 860 mm

**Weight:** 70 kg

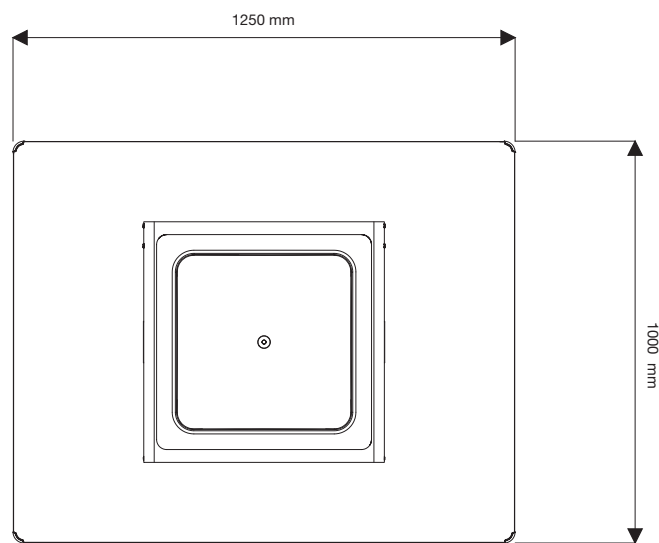
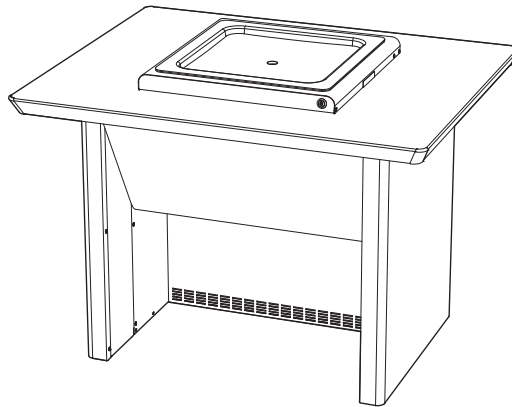

**Top View**

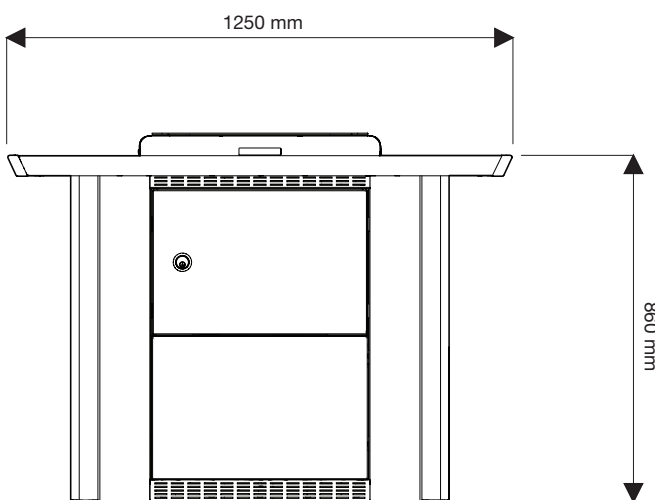

**Rear View**

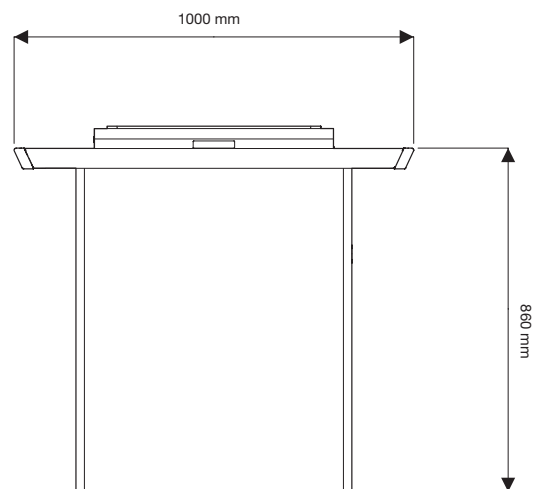

**Side View**