

CHRISTIE

Modular Cabinet Small Barbecue Cabinet

The classic Christie Modular Cabinet has set the standard for prefabricated public barbecue cabinets for over 30 years. Flat-packed, they are versatile, durable, and easy to assemble. Modular cabinets are built tough to withstand heavy use in the most demanding locations and harshest environments.



KEY FEATURES:

- Hygienic stainless-steel benchtop with low-impact corner inserts for added safety
- Heavy duty aluminium frame and stainless steel panels for complete recyclability and ultimate corrosion resistance
- Ventilated panels improve airflow, reducing moisture build-up and internal temperature to extend barbecue life
- Shipped flat-packed for easy site access and reduced freight costs
- Fast, simple assembly by any competent person
- Optional Waste Container Bracket provides a raised container platform improves safe handling and storage clearances

Product shown with our CC2 electric cooktop. Small cabinets can also be ordered with our natural gas or reticulated LPG cooktops.

Modular barbecue frames and doors are available off-the-shelf powder-coated in Dulux Surreal Effects Aztec Silver. The finish, created using tough polyester thermosetting powder, has an undulating texture with a pearl vein ripple.

AZTEC SILVER STANDARD PANEL COLOUR AND TEXTURE:

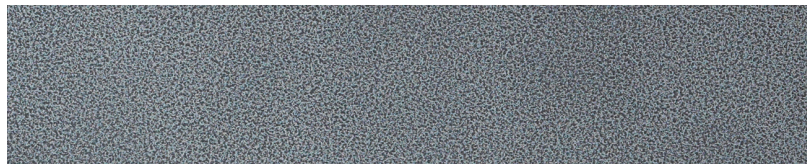

Custom colours and finishes may incur additional cost and lead time. Contact us to discuss our extensive colour options.

ACCESSORIES:

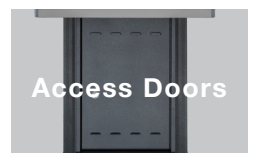
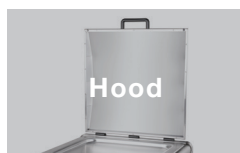

Modular Small Barbecue Cabinet

DIMENSIONS: (Standard Configuration)

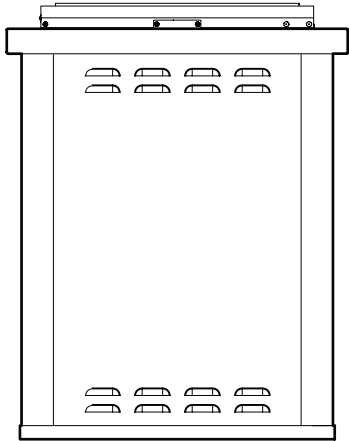
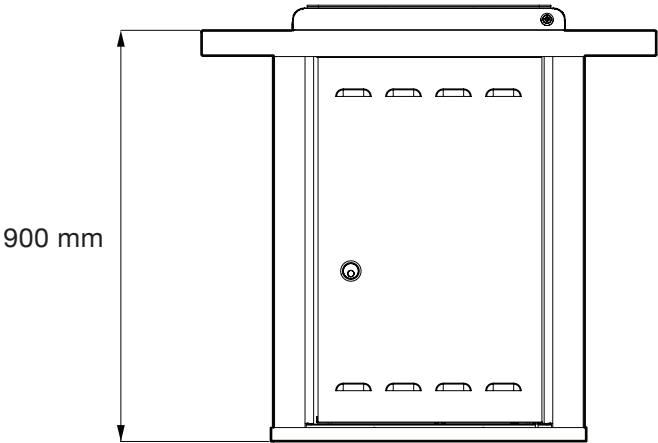
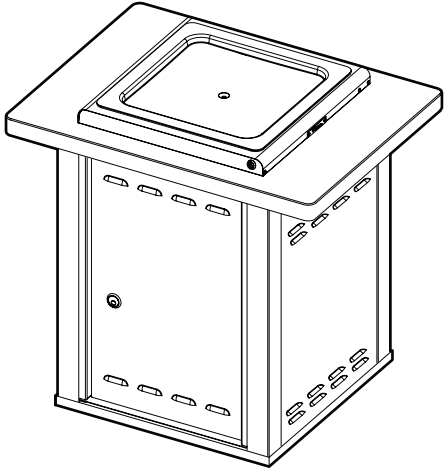
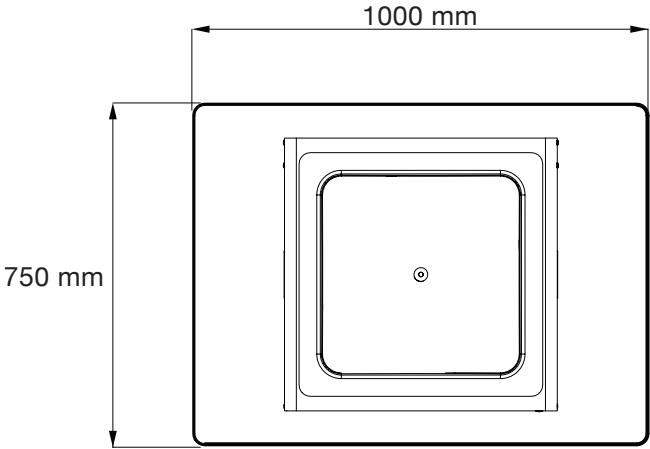

CUSTOM CONFIGURATIONS:

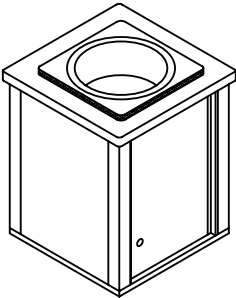

Small Modular with Sink