

CHRISTIE

Easy Drain Grease Trap

Our Easy-drain Grease Trap offers significant cleaning, environmental, and OH&S benefits. The fully welded stainless container is corrosion-resistant and is easy to drain, lift, and clean.



The Easy-drain Grease Trap is compatible with our accessible ICON and A-Series cabinets and can be retrofitted to other suitable cabinets using our [Christie Waste Container Bracket](#).

KEY FEATURES:

- Heavy-duty construction for ultimate durability
 - 304-grade stainless steel is corrosion-resistant, durable, and easy to clean
 - Fully welded to prevent leakage
 - Integrated partition separates oil from wastewater
 - Auto-levelling tap to empty without lifting
 - 12.5 L capacity for ease of handling
-

HOW IT WORKS:

An internal partition prevents oil from overflowing the container due to excessive water entry. Water flows underneath the partition and drains via the overflow port. The remaining water is drained via the integrated tap.

Easy Drain Grease Trap

DIMENSIONS:

Width 388 mm
Depth 295 mm
Height 170 mm

Tare Weight: 3.5 kg
Gross Weight: 16 kg
Capacity: 12.5 L

Front View

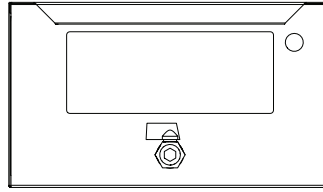

Isometric View

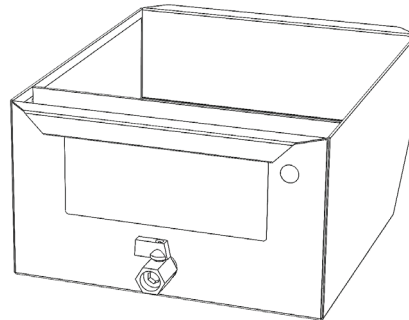

Top View

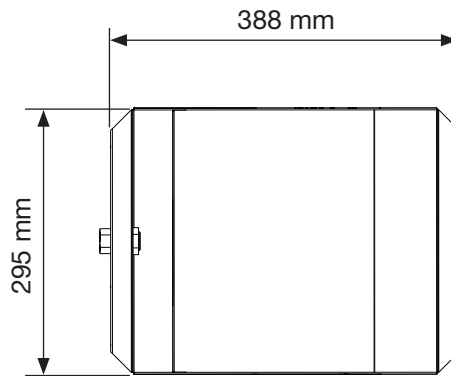

Side View

