

CHRISTIE

CC2 Gas Barbecue Cooktop V2 Trouble Shooting

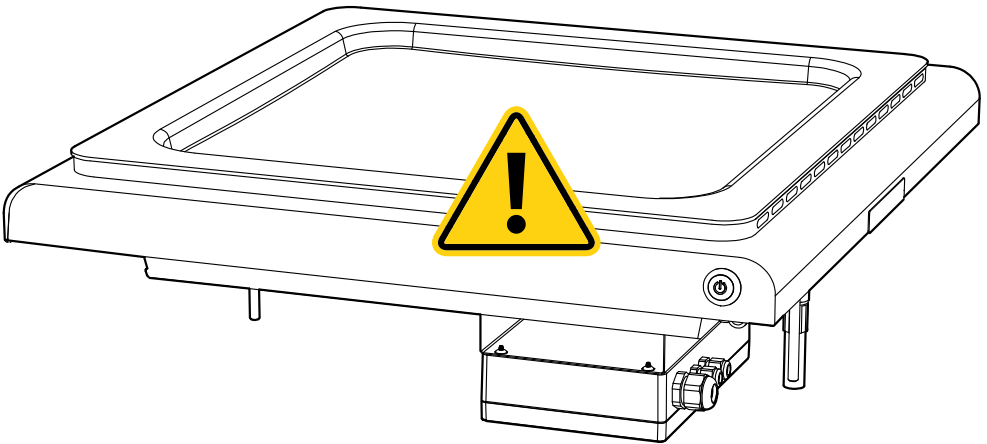

Part numbers 1214,1215
and 1216

This manual is an integral part of the appliance and must be kept in its entirety in an easily accessible location. **Read these instructions carefully before installing and using the appliance.**



WARNING: THIS APPLIANCE MUST ONLY BE SERVICED BY A LICENSED GAS FITTER OR SUITABLY QUALIFIED PERSON. DO NOT MODIFY ANY PART OF THE APPLIANCE.

The appliance does not respond when pressing the start button.

1. Check that the button has been depressed for at least 6 seconds
2. Open the access door under the appliance and confirm that power is available. For battery-powered units, measure the voltage with a good quality digital voltmeter. If the voltage is below 12.4 V DC under load, the battery is flat and needs recharging or replacement

The appliance turns on but does not ignite.

1. Contact a licensed gasfitter or suitably qualified person to check that there is gas supply available, and it is set to the correct operating pressure
2. If this is a built-in or non-Christie cabinet, contact a licensed gasfitter or suitably qualified person to ensure the structure has appropriate ventilation

If the fault persists, contact Christie customer support or your local technician for assistance, providing details of the fault and the appliance serial number. The CC2 cooktop barbecue has an automatic diagnostic system indicated by green/red flashing of the START/STOP button.

Diagnostic codes

Flashing green and red START/STOP button means an error has occurred and the appliance has entered diagnostics mode. The flashing sequence indicates a particular Fault Code, confirmed by a seven-second interval and audible “pip” sound. The Fault Code sequence repeats after a 15-second interval.

Troubleshooting chart Fault Code summary:

- Fault Code 1 will remain active until the power supply is turned off. You will not be able to operate the appliance on again until the fault is resolved
- Fault Code 2, 3 and 4 will remain active. Although it is possible to restart the appliance in this mode, it will re-enter fault mode until the fault is resolved
- Fault Code 5 will result in a 5-minute lockout. You may restart the appliance, but the fault will continue to flash on the START/STOP button
- Fault Code 6 appears if the push button has been stuck in the “on” position for five minutes or more. It will remain active until the power supply is turned off or the fault is repaired
- A constant audible “pip” sound with no flashing lights indicates a low voltage supply

Troubleshooting Chart

TABLE 2

1 Flash code	Faulty temperature sensor	Replace Thermistor. Contact Christie or your local technician
	Damaged connector	Replace Control Board. Contact Christie or your local technician
2 Flash code	Faulty temperature sensor lead	Replace Thermistor. Contact Christie or your local technician
	Lead not secure in the connector or disconnected from control board	Contact Christie or your local technician
3 Flash code	Not heating or food has been placed on the hotplate before reaching temperature	Remove food and attempt to start the appliance again. Wait for the cooking cycle to commence before placing food on the hotplate. Contact Christie or your local technician
4 Flash code	Not heating	Contact Christie or your local technician
5 Flash code	Maximum of three ignition attempts exceeded due to wind or environmental conditions	Wait 5 minutes and attempt to start the appliance again. Contact Christie or your local technician
	Maximum of three ignition attempts exceeded due to water in the gas burner	Wait for the water to evaporate and attempt to restart the appliance. Contact Christie or your local technician
	Maximum of three ignition attempts exceeded due to high, low, or no gas pressure	Check the gas supply and pressure. Contact Christie or your local technician
6 Flash code	The START/STOP button has been stuck in the on position for more than 5 minutes	Check the switch and replace if necessary. Contact Christie or your local technician

A CC2 Gas Technical Service Manual is available from Christie upon request, for use by suitably qualified persons only. This manual contains detailed information on how to service and repair the appliance.

